



**WOOLWICH**  
**TOWNSHIP**



# Accessory Dwelling Unit Information Package

Effective September 1, 2024

Updated November 29, 2024

**If you are looking to build an Accessory Dwelling Unit (ADU) in the Township of Woolwich, the following provides a checklist and summary of the steps required in the development process, from conception to construction.**

**Please ensure the intent of the proposal adheres to the definition of an ADU as set out in the Zoning By-law:**

**“A separate, self-contained dwelling unit which is subordinate to and located within the principle dwelling unit and/or permitted accessory building located on the same lot”**

- **STEP 1 – ADU ZONING COMPLIANCE CERTIFICATE APPLICATION**

Complete the ADU Zoning Compliance Certificate Application, ensuring all checkboxes have been marked appropriately and all provisions have been read in each section.

STEP 1A – Zoning

STEP 1B – Development Engineering

STEP 1C – Building

- **STEP 2 – CREATE PRELIMINARY PLANS AND DRAWINGS**

Create plans and drawings to accompany the ADU Zoning Compliance Certificate Application, including a Site Plan, Floor Plan, Elevation, and other required details.

STEP 2A – Site Plan Requirements

STEP 2B – Floor Plan Requirements

STEP 2C – Elevation Drawing Requirements

STEP 2D – Additional Drawings

- **STEP 3 – OBTAIN ZONING COMPLIANCE CERTIFICATE**

(Timeline: 4-6 weeks review for zoning compliance certificate)

STEP 3A – Submit ADU Zoning Compliance Certificate Application and Drawings

STEP 3B – Fees

STEP 3C – Receive Township Comments, Questions, and Feedback

Receive and review staff comments, modifying plans and drawings as indicated by staff and address concerns.

STEP 3D – Receive Certificate

- **STEP 4 – BUILDING PERMIT APPLICATION**

(Timeline: 2 day review for Complete Application, 10 day review for building permit application)

STEP 4A – Preparing Final Plans and Drawings

STEP 4B – Complete the Building Permit Application Form

STEP 4C – Resolve Deficiencies

STEP 4D – Fees

STEP 4E – Receive Building Permit. Construction of the ADU may begin.

- **Additional information such as drawings, application forms, and frequently asked questions can be found in the Appendices.**
-

## ADU ZONING COMPLIANCE CERTIFICATE APPLICATION FEES

Fees are broken out per stage of application below. Please note all fees are subject to change. Refer to the Township Fees and Charges By-law for current rates and the respective websites for the Public and Separate School Boards for Education Development Charge Rates.

### Planning Department Fees:

\$ 250.00 - Zoning Compliance Certificate

### Building Department Fees:

The fees below are typical and separated by ADU type. Additional fees may apply based on the proposed scope of work. For complete list of fees, refer to the Building Fees Schedule on the Township's website.

Primary Dwelling Renovations to create ADUs (Basement, second floor, attic, etc.)

\$350.00 – Accessory Dwelling Units

\$0.50 /sq ft – Interior Finishing or Alteration/Renovation

Detached Buildings and Additions to create ADUs (tiny house, granny suite, etc.)

\$1.38 /sq ft – Residential Occupancies

All ADU Types

\$8.50 per plumbing fixture

\$200.00 – New exterior basement entrance (stairs and retaining wall)

\$125.00 – New door/window opening

### Development Charge Fees:

Proposals seeking to create an ADU as prescribed by the Township's Zoning By-Law are exempt from Regional and Township Development Charges. Educational Development Charge rates may apply.

Charge Type & Rate	Dates Valid From
Public School Board (WRDSB) - \$3,148/unit	June 1, 2024, to May 31, 2025
Separate School Board (WCDSB) - \$1,739/unit	June 1, 2024, to May 31, 2025

For more information, and current Educational Development Charge Rates, please visit the links below:

Public School Board- <https://www.wrdsb.ca/planning/education-development-charges/>

Additional fees may be required to complete a lot grading plan, or for Minimum Distance Separation (MDS) calculations on agricultural lands.

---



**THE CORPORATION OF THE TOWNSHIP OF WOOLWICH**  
 P.O. Box 158, 24 Church Street West, Elmira, ON N3B 2Z6  
 PHONE: 519-669-1647 or 1-877-969-0094  
 EMAIL – [planning@woolwich.ca](mailto:planning@woolwich.ca)

**APPLICATION FOR ZONING COMPLIANCE CERTIFICATE**

means a Certificate of Occupancy pursuant to Section 34(6) of the *Planning Act* and  
 Section 2.12 of Zoning By-law 26-2024

Owner _____	Applicant _____
Address _____	Address _____
_____	_____
_____	_____
Postal Code _____	Postal Code _____
Telephone Number _____	Telephone Number _____
Email _____	Email _____

Property Description:

Municipal Address \_\_\_\_\_

Proposed Use:

\_\_\_\_\_

\_\_\_\_\_

Floor Area by Specific Use (list below or provide details on required floor plan)

Use _____	Area _____
Use _____	Area _____
Use _____	Area _____

Number of Parking Spaces Proposed \_\_\_\_\_ Number of Loading Spaces Proposed \_\_\_\_\_

\_\_\_\_\_  
 Date Signature

**This application must be accompanied by a detailed SITE PLAN, FLOOR PLAN, and ELEVATION PLAN drawn to scale and the fee attached.**

**NOTE: Copies of Valid Diplomas, Certificates and/or Licenses of Registration will be required at time of submission for all proposed practitioners, including but not limited to massage, naturopathic, physiotherapy, and reflexology.**

=====

**FOR OFFICE USE ONLY:**

Roll Number _____	Receipt Number _____
Date Received _____	Official Plan and Zoning _____

## STEP 1 - ADU ZONING COMPLIANCE CERTIFICATE APPLICATION

Please complete the following sections to better understand if the proposal will meet Township requirements and provide staff with the necessary information. Requirements are outlined below and will guide interested applicants through the Township's administrative process to ensure the proposal is permitted.

Township staff are available to assist with the completion of this ADU Zoning Compliance Certificate Application upon request.

### Grand River Conservation Authority (GRCA)

Is the property located within the GRCA's Regulation Limit?

Yes       No

A property is in GRCA's Regulation Limit when it is within the red outline on our Zoning Map. Please use our Zoning By-law Map available here: [\[Zoning Map\]](#) or through our website at <https://woolwich-geohub-woolwich.hub.arcgis.com/> followed by 'Web Maps', and then click on 'Woolwich Zoning By-Law 26-2024'.

If yes, a permit may be required from the GRCA. Please visit [www.grandriver.ca](http://www.grandriver.ca), or email [planning@grandriver.ca](mailto:planning@grandriver.ca). The Township will not begin review of the proposal if permission from the GRCA has not yet been granted.

### Lot Grading Certification

Is the property located in a subdivision built in the last 10 years?

Yes       No

A property located within a subdivision built in the last 10 years may not have received its lot grading certification. Most subdivisions will have a registered development agreement. If this is the case, you will not be permitted to alter the lot grading with the proposed ADU. This includes exterior entrances, walkways, or landings.

Please consult with your home's builder if you are unsure if the lot grading has been certified or contact [deveng@woolwich.ca](mailto:deveng@woolwich.ca) to learn more.

---

## STEP 1A – Zoning

1. Check the current Zoning of the Property. If the zone is not listed below, an ADU is not permitted on the property.

A       R-1       R-2       R-3       R-4       R-5  
 R-6       R-7       MU-1       MU-3       MU-4       C-2

To determine the property's zoning, use our Zoning By-law Map available here: [\[Zoning Map\]](#) or through our website at <https://woolwich-geohub-woolwich.hub.arcgis.com/> followed by 'Web Maps', and then click on 'Woolwich Zoning By-Law 26-2024'.

Follow the directions on the left-hand side of the screen. Using the search bar, locate the property and click on the parcel. Once selected, click the right-hand arrow at the bottom of the black box to navigate to the second page. Here you will find your Zone.

2. Indicate your proposed ADU type by checking only one of the boxes below. Use the Zone specific ADU requirements below to guide your plans and drawings.

**Floor Area** is defined as the area between exterior walls and firewalls, including interior walls, but excluding exits, service spaces, and areas such as garages, carports, porches, decks, terraces, unheated sunrooms, balconies, and spaces with ceilings under 1.95 metres tall.

**Building Lot Coverage** is defined as the percentage of the lot area covered by all buildings on the property, including covered front porches, but excluding swimming pools, rear or side decks, uncovered front porches, patios, ground-mounted or wall attached mechanical equipment, children play-structures and flag poles and landscaping.

**Building Size** means the total area of a lot covered or intended to be covered by the proposed building.

### TYPE 1 – ATTACHED ADU (Basement units, additions, or second floors)

- Primary** (Addition to the existing dwelling or conversion of space within the primary dwelling unit)

ADU must not exceed 95 square metres or 40% of the floor area of the primary dwelling, whichever is lesser.

- Basement**

If located in a basement, an ADU is permitted to occupy the entire basement.

### TYPE 2 – DETACHED ADU (Garden suites, tiny houses, or mobile homes)

- A**

ADU must not exceed 95 square metres of floor area, and 112 square metres in building size. Maximum lot coverage of 20%. An Accessory Building is permitted in addition to an ADU.

Alternatively, mobile homes are permitted and are restricted to a maximum width of two sections each measuring 4.88 metres (16 feet).



- R-1**  
ADU must not exceed 95 square metres of floor area, and 100 square metres of building size. Maximum lot coverage of 30%. An Accessory Building is permitted in addition to an ADU.
- R-2**  
ADU must not exceed 95 square metres of floor area. Accessory Buildings must not total more than 70 square metres of building size. Maximum lot coverage of 50%.
- R-3, R-4, R-5, MU-1, MU-3, MU-4**  
ADU must not exceed 95 square metres of floor area. Accessory Buildings must not total more than 10% of the lot area or 70 square metres of building size, whichever is lesser. Maximum lot coverage of 60%.
- R-6, R-7**  
ADU must not exceed 95 square metres of floor area. Accessory Buildings must not total more than 15 square metres of building size. Maximum lot coverage of 60%.
- C-2**  
ADU must not exceed 95 square metres of floor area. Accessory Buildings must not total more than 10% of the lot area or 70 square metres of building size, whichever is lesser. Maximum lot coverage of 40%.

### Building Size Example

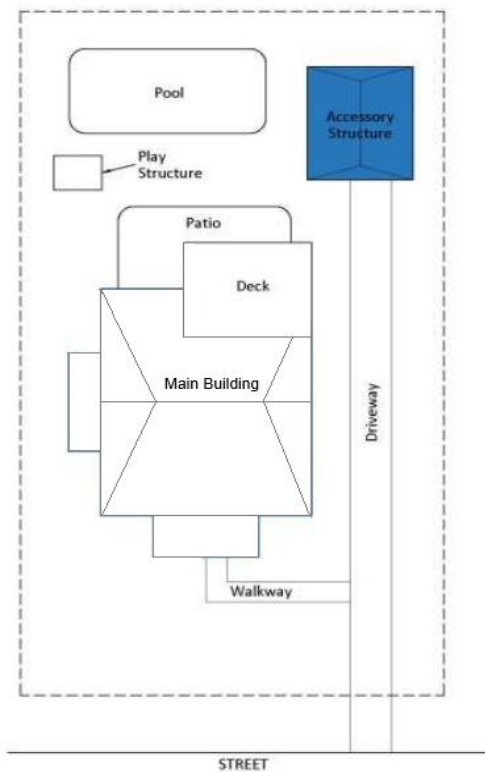

### Lot Coverage Example

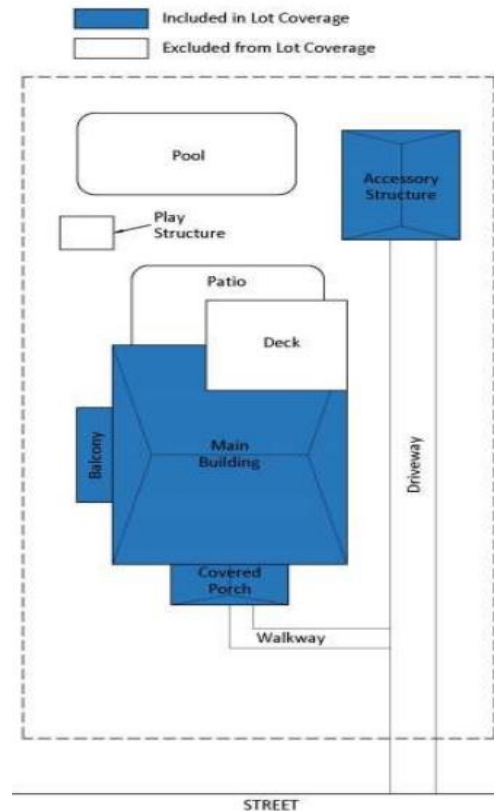

**Note:** O. Reg 299/19 is proposing a lot coverage of up to 45% for all lots with an ADU.

3. Indicate the proposed Roof Style and Height of the ADU by checking one of the boxes:

**Note:** Accessory Dwelling Units must respect height restrictions under the Zoning By-law. Heights are measured from the average grade level to the midpoint of a peaked roof and to the top of a flat roof.

### TYPE 1 – ATTACHED ADU

(Height restrictions vary depending on the applicable zone)

- R-1, R-2, R-3, R-4, R-5  
Allowable height of 10.5 metres maximum.
- R-6, R-7  
Allowable height of 12.5 metres maximum.
- A, C-1, MU-1, MU-3, MU-4

Maximum heights vary subject to the zone. Contact Staff for more information.

### TYPE 2 – DETACHED ADU

(Height restrictions vary depending on roof type)

- Peaked Roof  
Allowable height of 4.5 metres maximum.
- Flat Roof  
Allowable height of 3.7 metres maximum.

### Elevation and Roof Styles

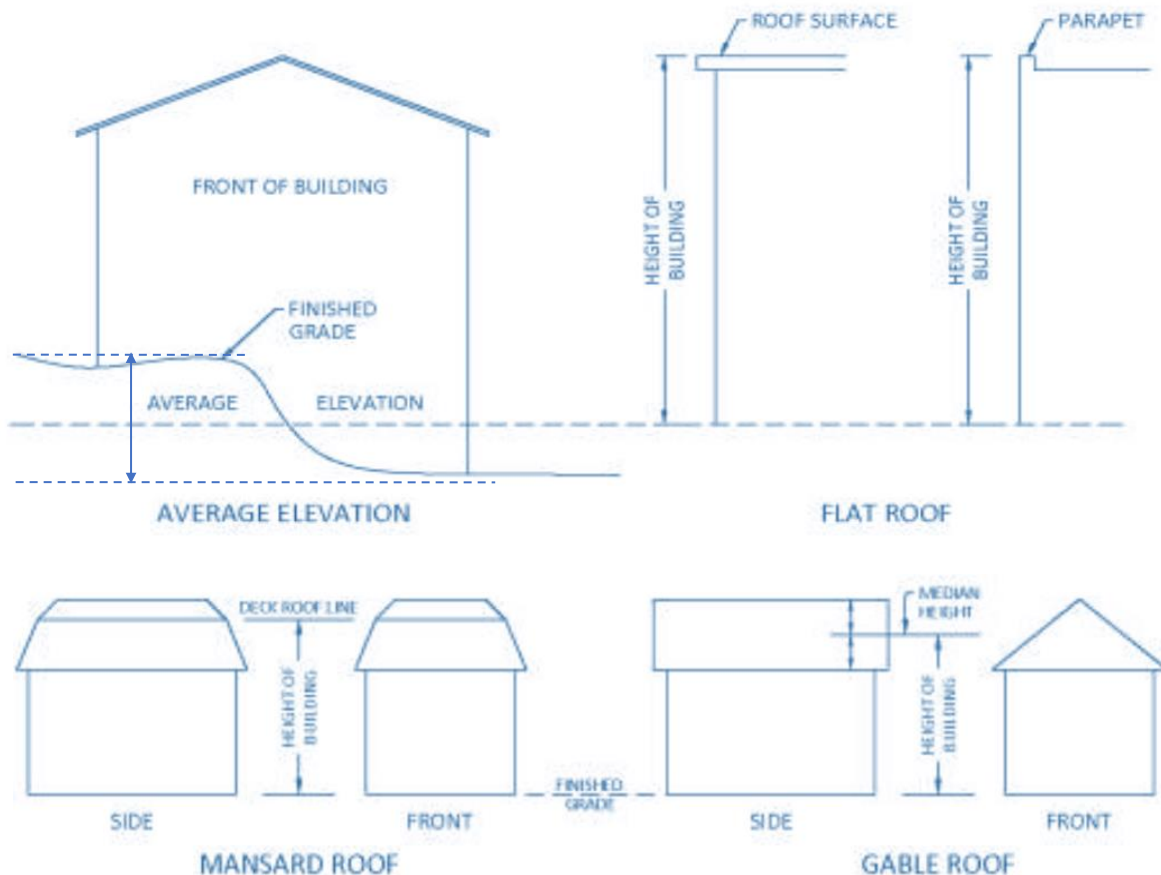



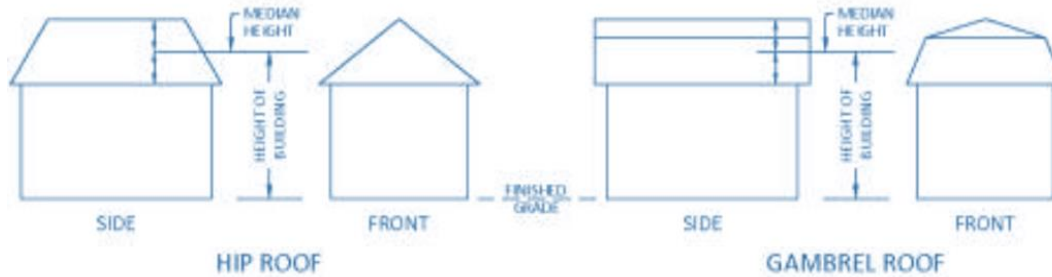

4. How many bedrooms are proposed? No more than 2 bedrooms are permitted per ADU.  
 1 Bedroom       2 Bedrooms

5. Where is the proposed ADU located? ADUs are not permitting the front yard and must be within 30 metres of the farm cluster in the Agricultural Zone.  
 Rear Yard       Side Yard       Basement       Farm Cluster

6. Does the ADU respect the minimum 4 metre rear yard setback and the minimum 1.2 metre side yard setback?  
 Yes       No       N/A (Basement)

An attached ADU must respect applicable zone setbacks as well as yard projections. For more information, please review the Zoning By-law or contact Staff.

7. Does the ADU respect Minimum Distance Separation (MDS) setbacks? A Minimum Distance Separation calculation is only required in the Agricultural Zone.  
 Yes       No       Not Applicable

Minimum Distance Separation (MDS) setbacks apply to ADUs in proximity to livestock facilities, manure storages and anaerobic digesters. Please refer to the [Minimum Distance Separation Document](#), as amended, for applicable separation distances.

8. How many total parking spaces are proposed for the property? One parking space is required per dwelling unit. Parking spaces can be in a garage or stacked in a driveway.  
 1 Space     2 Spaces     3 Spaces     4 or more spaces

9. Are the proposed parking spaces at least 5.5 metres long and 2.75 metres wide?  
 Yes       No

10. Does the parking proposal meet the required driveway provisions?  
 Yes       No

The driveway must be shared with the primary dwelling.

For single-detached dwellings with a lot frontage less than 10 metres, or for semi-detached or townhouses with a one-car garage attached, the maximum driveway width is 3.66 metres or 60% of the lot width, whichever is less. For low-density residential areas other than R-1 and R-2, the maximum driveway width is 6 metres.

11. Does the garage meet the garage sizing provisions?  
 Yes       No

A one car garage must have a minimum width of 3.35 metres and a minimum depth of 5.5 metres. (Distances measured from between the centres of the walls)

**STEP 1B – Development Engineering**

If the proposed ADU is detached, a grading plan will be required and must be prepared by a Professional Engineer. If exterior work is proposed for the creation of an ADU inside an existing dwelling unit, a grading plan may be required. Further requirements will be provided once staff review is complete.

1. Is the primary dwelling more than 5 years old? If no, the property may not yet have received Lot Grading Certification. If no Certificate has been issued, the home builder's approval may be required.

Yes       No

2. Will the driveway be modified to accommodate parking for the proposed ADU?

Yes       No

If yes, list the total number of spaces being provided: \_\_\_\_\_

3. Does the ADU construction include any of the following proposed changes to an existing building or the property?

Structural Changes       Egress Changes  
 Grading Changes       New Exterior Entrance  
 Servicing Changes

4. Water Supply Type:       Municipal       Communal  
    Individual       Other (specify): \_\_\_\_\_

5. Sewage Disposal Type:       Municipal       Communal  
    Individual       Other (specify): \_\_\_\_\_

6. Storm Drainage Type:       Sewers       Ditches  
    Swales       Other (specify): \_\_\_\_\_

7. Will the proposed development change any existing pervious materials to impervious materials?

Yes       No

**Note : Swales must not be obstructed or disturbed from two feet of the lot line.**

---

## **STEP 1C – Building**

See below a list of commonly designed spaces within a dwelling unit, and their size and window requirements. All room measurements are to be taken between finished walls. When designing your ADU, please have regard for this information.

### *Living Area (Designated Separate)*

- Minimum required floor area of 13.5 square metres, window size to be at least 5% of floor area.

### *Dining Area (Designated Separate)*

- Minimum required floor area of 7 square metres, window size to be at least 5% of floor area.

### *Kitchen (Designated Separate)*

- Minimum required floor area of 4.2 square metres, no minimum window size

### *Combined Living, Dining, Kitchen Area, in a One Bedroom Unit*

- Minimum required floor area of 11 square metres.

### *Primary Bedroom (Without built-in closet)*

- Minimum required floor area of 9.8 square metres, window size to be at least 2.5% of floor area.

### *Other Bedrooms (Without built-in closet)*

- Minimum required floor area of 7 square metres, window size to be at least 2.5% of floor area.

### *Bathroom*

- No minimum, provided there is sufficient space for a sink, toilet, and shower/bath.

### *Combined Sleeping, Living, Dining Area and Kitchen Space*

- Minimum required floor area of 13.5 square metres.

When designing your ADU, consider the minimum ceiling height dimensions per unit location, as noted below:

### *Basement*

- Minimum height of 1.95 m (6' 4<sup>3</sup>/<sub>4</sub>" ) over the entire required floor area, including the route inside the unit leading to the exit.

### *Attic*

- At least 50% of the required floor area has a ceiling height of 2.03 metres (6' 8"), but this does not include areas with low ceilings less than 1.4 metres (4' 7") high. If an attic space ADU is considered, there are additional requirements that must be met. Please consult with Building Department Staff for further information.

### *All Other ADUs*

- Minimum required height of 2.3 metres (7'6.5").

### *Mobile Homes*

- Mobile homes will need to demonstrate they are property anchored if using piles or blocks through engineering drawings. Foundations do not need engineering but will require a lot grading plan.
-

## **STEP 2 – CREATE PRELIMINARY PLANS AND DRAWINGS**

Prepare or revise all plans and drawings using the provided information in STEP 1A, 1B, and 1C to ensure the proposal all identified requirements. Please note that further requirements based on the specific scope of work may be provided after staff review.

Listed below are the requirements for each drawing and examples are included to guide interested applicants. Alternatively, a design professional can be retained to complete drawings on behalf of the applicant.

### **STEP 2A – Site Plan Requirements**

**Note:** Complete the site plan on a minimum 8½" X 11" page and ensure legibility.

1. The boundaries and dimensions of the subject property
  2. The location, size and type of all existing and proposed buildings and structures on the subject property, indicating distance of the buildings or structures from the front yard lot line, rear yard lot line and the side yard lot lines.
  3. The approximate location of all natural and artificial features on the subject property and on the land that is adjacent to the subject land. Examples include buildings, railways, roads, watercourses, drainage ditches, river or stream banks, wetlands, wooded areas, wells and septic area.
  4. The current uses on the land that is the subject of the application.
  5. The location, width and name of any roads within or abutting the subject property, indicating whether it is an unopened road allowance, a public traveled road, a private road or a right of way.
  6. The location and nature of any easements affecting the subject property.
-

# SITE PLAN EXAMPLE

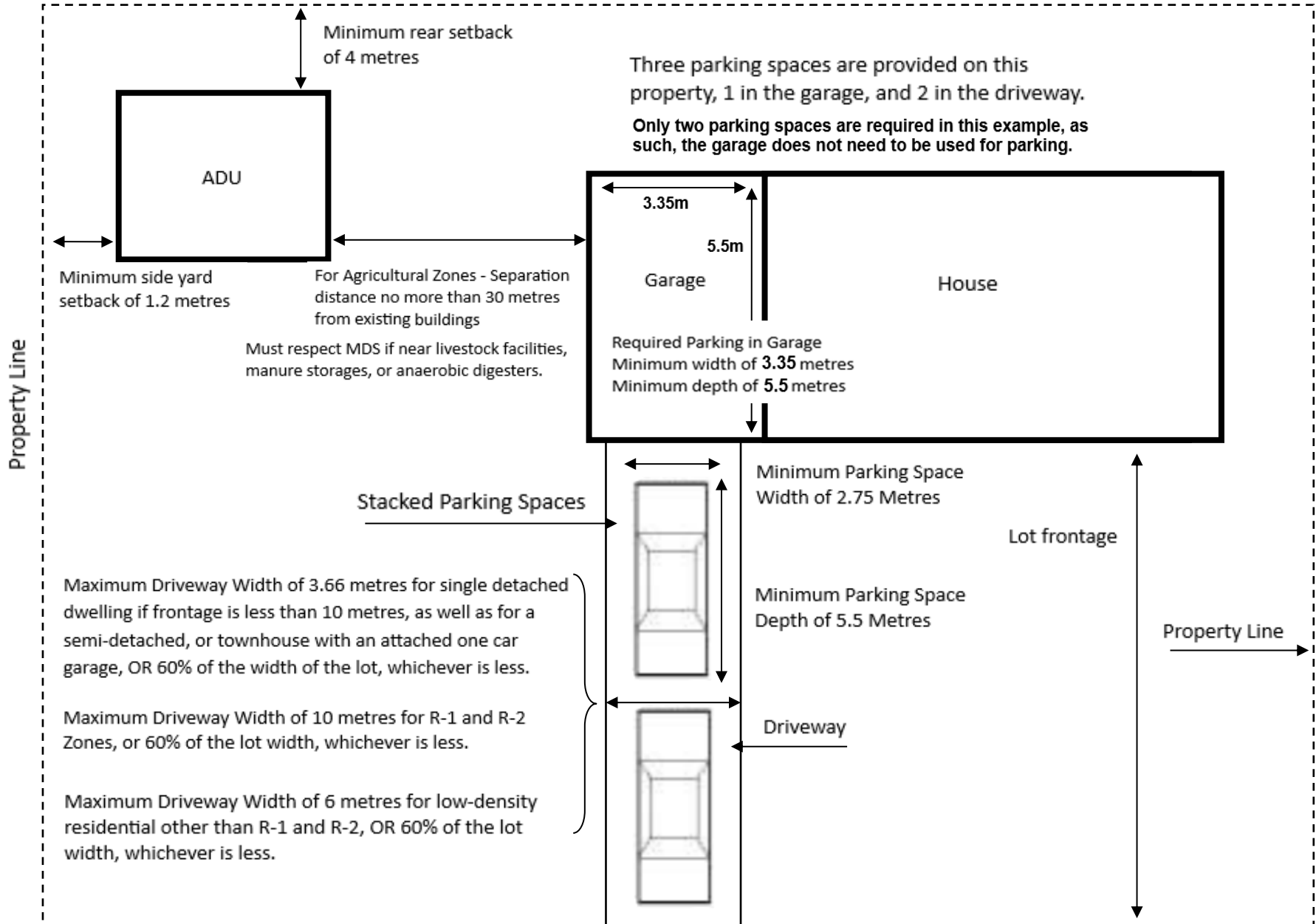

**STEP 2B – Floor Plan Requirements**

**Note:** Complete the floor plan on a minimum 8½" X 11" page and ensure legibility.

1. Overall building and interior room dimensions and labels.
2. Type and size of windows and doors. Label all egress windows/doors.
3. Note all stairs, vestibules, attached porches, and other major structural details.
4. The total floor area and lot coverage of the proposed building.
5. All new and existing plumbing fixtures and appliances.
6. All interior walls, closets, major appliances, stairs, and major details.
7. Ceiling height maximum and minimums in the building.

**See sample drawing attached. This drawing is sufficient for initial application and review. Further information will be required for a building permit application, including but not limited to HVAC information, egress details, fire separation details, and septic information (if applicable).**

---



### Example of early-stage floor plan, sufficient for Steps one (1) through three (3)

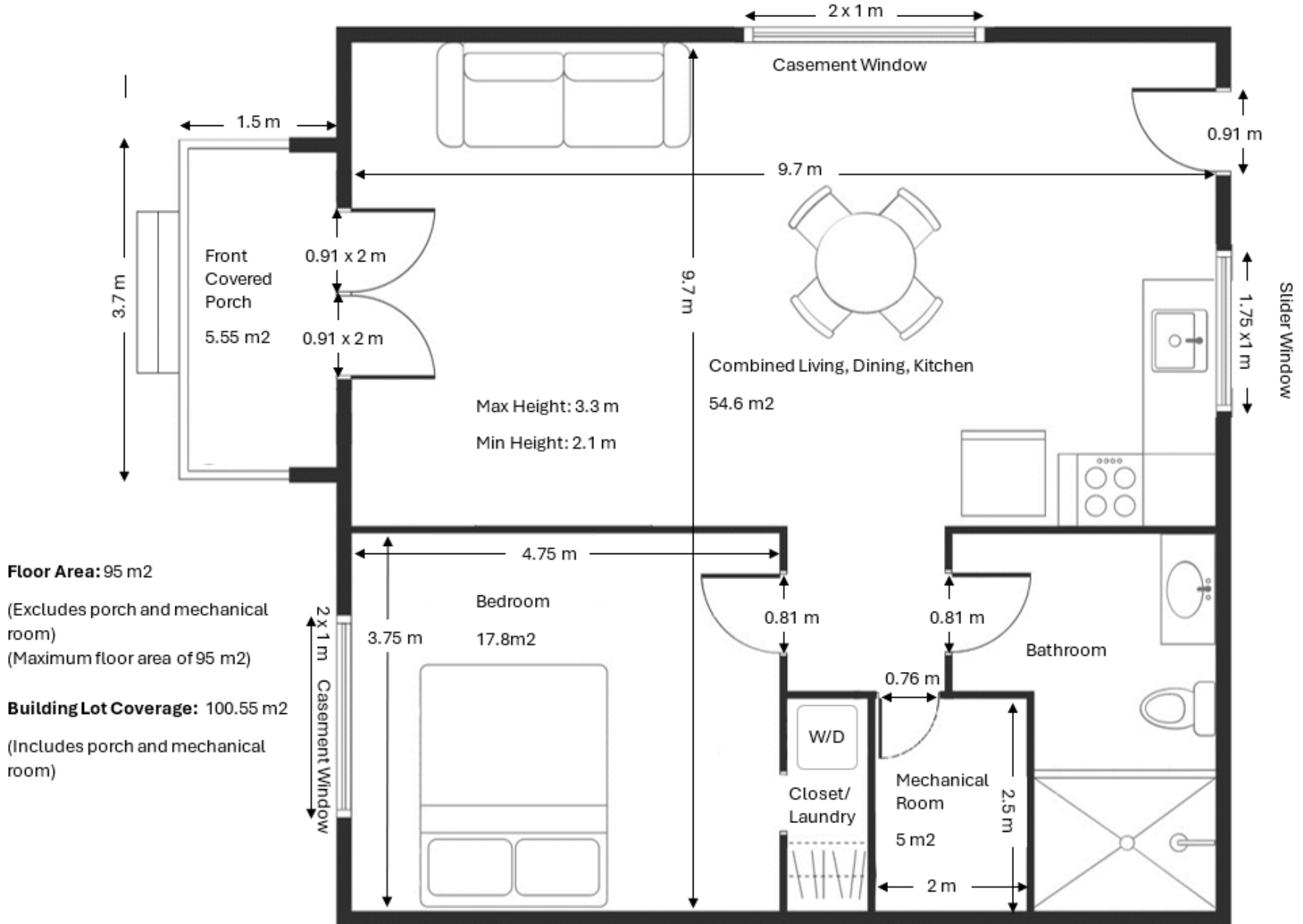

## STEP 2C – Elevation Drawing Requirements

**Note:** Complete the elevation drawing on a minimum 8½” X 11” page and ensure legibility

1. Height of the ADU from Grade to Midpoint.
2. Elevation labels
3. Porches (if applicable)

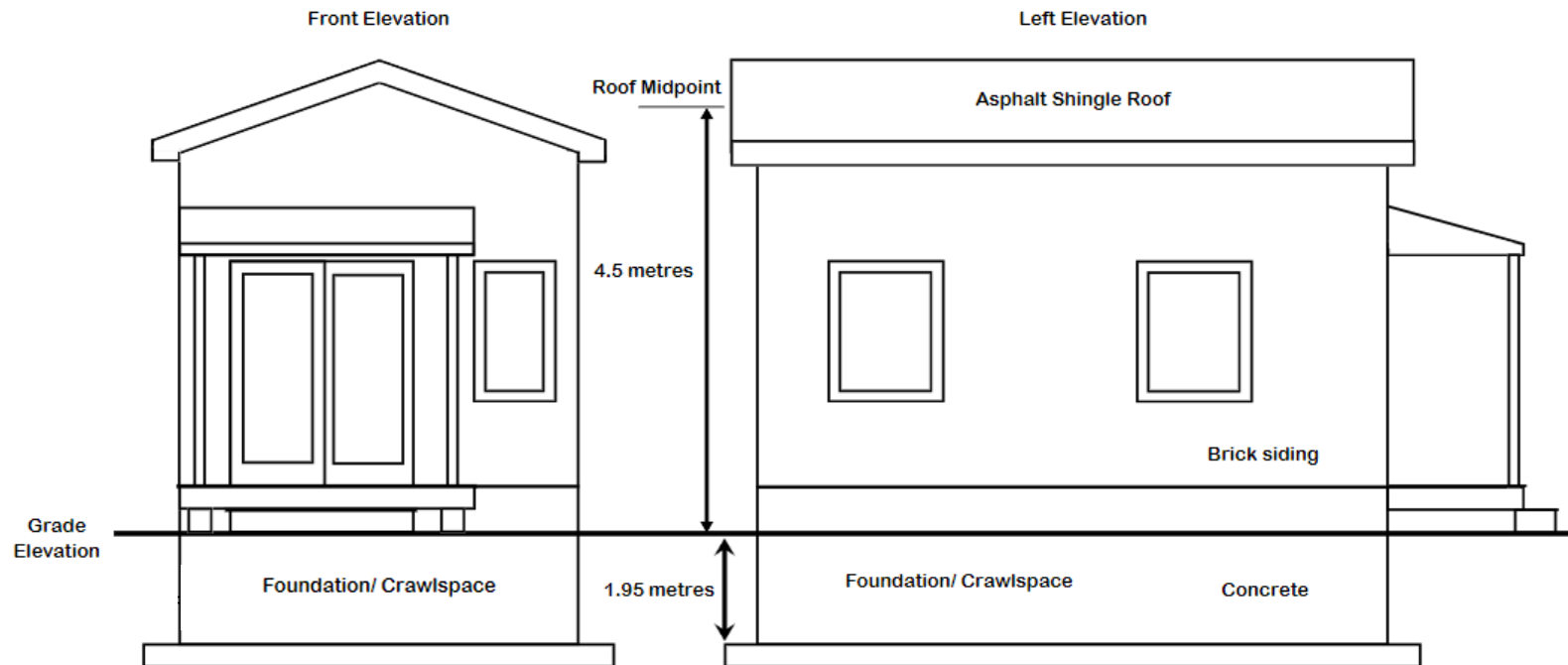

### **STEP 3 – OBTAIN ZONING COMPLIANCE CERTIFICATE**

By the end of step 3, all deficiencies will have been addressed, revised drawings submitted (if applicable), and planning fees paid. The applicant will receive their Zoning Compliance Certificate.

#### **STEP 3A – Submit ADU Zoning Compliance Certificate Application and Drawings**

The ADU Zoning Compliance Certificate Application from STEP 1A and 1B shall be submitted alongside the floor plan, site plan, and elevation drawings. Additional plans and drawings providing greater detail may also be submitted but are not necessary at this stage.

Once completed, please submit drawings and documents to the Planning Department in-person or via email at the following addresses:

P.O. Box 158, 24 Church Street West, Elmira, ON N3B 2Z6

PHONE: 519-669-1647 or 1-877-969-0094

EMAIL – [planning@woolwich.ca](mailto:planning@woolwich.ca)

#### **STEP 3B - Fees**

The Zoning Compliance Certificate fee is \$250.00 fee (2024). This fee must be paid in conjunction with the submission of the ADU Zoning Compliance Certificate Application. This fee is subject to change. Please refer to the Fees and Charges By-law for current fee rates.

Fees can be paid in person by cash, cheque, or debit at 24 Church Street West, in Elmira, or by mailing a cheque to P.O. Box 158, 24 Church Street West, Elmira, ON N3B 2Z6

#### **STEP 3C – Receive Township Comments, Questions, and Feedback**

Township staff will review the submission and collect comments from required departments. The interested applicant will be contacted and provided comments with respect to the proposed ADU. Any concerns and required changes will be addressed by the applicant and a resubmission of drawings and documents may be required.

Once all outstanding concerns are resolved, staff will contact the applicant advising the Zoning Compliance Certificate has been approved.

#### **STEP 3D – Receive Certificate**

Once The Zoning Compliance Certificate has been issued, the interested applicant may proceed with the Building Permit Application.

---

## **STEP 4 – BUILDING PERMIT APPLICATION**

Once the Zoning Compliance Certificate has been issued, a Building Permit Application shall be submitted. The steps for applying for a Building Permit are noted below.

### **STEP 4A – Prepare Final Plans and Drawings**

For Building Permit Application purposes, the following items are required. Further information may be required on a project-specific basis.

1. A completed application form, including the Schedule 1: Designer Information form
2. A copy of the approved Zoning Compliance Certificate issued by Planning staff
3. Comprehensive construction drawings including, but not limited to, the following:
  - a. Footing, Foundation, Floor, and Roof (Truss) Plans as applicable
  - b. Elevation views showing structure height, average grade, and exterior openings
  - c. Cross Sections indicating wall and roof construction and any items that are not typical

4. Septic system information, if applicable

A septic review is required when adding new plumbing fixtures, bedrooms, or more than 15% new floor area of the existing structure.

Construction drawings must indicate the following information. See sample drawings in Appendix B

All room names and dimensions, including all door locations and door sizes (width and height)

1. All new and existing window locations, types (ie: slider, casement, awning, etc.), sizes (width and height) and exterior window well locations
  - a) Glass area of each window and size of opening when window is in the open position (refer to egress window detail for requirements)
2. Location of stairs and doors into other dwelling unit(s)
3. Any new or existing exterior doors and/or below-grade entrances
4. Ceiling height (below existing mechanical fixtures) and type of finish in all rooms
5. Horizontal and vertical fire separation information and locations, or sprinkler information if applicable
6. Location and type of smoke alarms and carbon monoxide detectors
7. Location of all plumbing fixtures, noting access to laundry facilities
8. Any portion of the unit that is to be retained for the primary unit's use

### **Electrical Safety Authority (ESA) Inspections**

A Certificate of Acceptance issued by the Electrical Safety Authority (ESA) will be required at the end of the project for any new or existing Accessory Dwelling Unit. The certificate is in addition to any additional electrical permits that may be required. Please contact the ESA directly for more information regarding their permit requirements and process.

---

**STEP 4B – Submit Building Permit Application**

Complete the Building Permit Application form found in Appendix A. Submit the form, construction drawings and all other required details to the Building Department, in-person or via email at the following addresses:

P.O. Box 158, 24 Church Street West, Elmira, ON N3B 2Z6

PHONE: 519-669-1647 ext. 6042 or 1-877-969-0094

EMAIL – [buildingpermits@woolwich.ca](mailto:buildingpermits@woolwich.ca)

**STEP 4C – Resolve Deficiencies**

Once the building permit application has been received, staff will review and provide comments, which must then be address by the applicant. A resubmission or additional information may be required. Once all outstanding deficiencies are addressed, staff will send an invoice for the building Permit with payment options and instructions.

**STEP 4D – Pay Fees and Receive Permit documents**

Refer to the Fees outlined on page 3 for a list of typical Building Permit fees. Fees listed are subject to change and additional fees may apply based on the complete scope of work. Please refer to the Township Fees and Charges By-Law for a list of full fees and current rates.

Once all fees are paid, the Building Permit will be issued and related documents sent to the applicant. Construction of the ADU may begin.

---

# **Appendix A: Building Permit Application Forms**





<b>For use by Principal Authority</b>			
Application number:		Permit number (if different):	
Date received:		Roll number:	
<b>Application submitted to:</b> _____ (Name of municipality, upper-tier municipality, board of health or conservation authority)			
<b>A. Project information</b>			
<b>Building number, street name</b>		Unit number	Lot/con.
<b>Municipality</b>	<b>Postal code</b>	Plan number/other description	
<b>Project value est. \$</b>		<b>Area of work (m<sup>2</sup>)</b>	
<b>B. Purpose of application</b>			
<input type="checkbox"/> New construction	<input type="checkbox"/> Addition to an existing building	<input type="checkbox"/> Alteration/repair	<input type="checkbox"/> Demolition <input type="checkbox"/> Conditional Permit
<b>Proposed use of building</b>		<b>Current use of building</b>	
<b>Description of proposed work</b>			
<b>C. Applicant</b>			
<b>Applicant is:</b>		<input type="checkbox"/> Owner or	<input type="checkbox"/> Authorized agent of owner
Last name		First name	Corporation or partnership
Street address		Unit number	Lot/con.
Municipality	Postal code	Province	E-mail
Telephone number	Fax	Cell number	
<b>D. Owner (if different from applicant)</b>			
Last name		First name	Corporation or partnership
Street address		Unit number	Lot/con.
Municipality	Postal code	Province	E-mail
Telephone number	Fax	Cell number	

<b>E. Builder (Optional)</b>					
Last name	First name	Corporation or partnership (if applicable)			
Street address		Unit number	Lot/con.		
Municipality	Postal code	Province	E-mail		
Telephone number	Fax		Cell number		
<b>F. Tarion Warranty Corporation (Ontario New Home Warranty Program)</b>					
i. Is proposed construction for a new home as defined in the <i>Ontario New Home Warranties Plan Act</i> ? If no, go to section G.		<input type="checkbox"/>	Yes	<input type="checkbox"/>	No
ii. Is registration required under the <i>Ontario New Home Warranties Plan Act</i> ?		<input type="checkbox"/>	Yes	<input type="checkbox"/>	No
iii. If yes to (ii) provide registration number(s): _____					
<b>G. Required Schedules</b>					
i) Attach Schedule 1 for each individual who reviews and takes responsibility for design activities.					
ii) Attach Schedule 2 where application is to construct on-site, install or repair a sewage system.					
<b>H. Completeness and compliance with applicable law</b>					
i) This application meets all the requirements of clauses 1.3.1.3 (5) (a) to (d) of Division C of the Building Code (the application is made in the correct form and by the owner or authorized agent, all applicable fields have been completed on the application and required schedules, and all required schedules are submitted).		<input type="checkbox"/>	Yes	<input type="checkbox"/>	No
ii) This application is accompanied by the plans and specifications prescribed by the applicable by-law, resolution or regulation made under clause 7(1)(b) of the <i>Building Code Act, 1992</i> .		<input type="checkbox"/>	Yes	<input type="checkbox"/>	No
iii) This application is accompanied by the information and documents prescribed by the applicable by-law, resolution or regulation made under clause 7(1)(b) of the <i>Building Code Act, 1992</i> which enable the chief building official to determine whether the proposed building, construction or demolition will contravene any applicable law.		<input type="checkbox"/>	Yes	<input type="checkbox"/>	No
iv) The proposed building, construction or demolition will not contravene any applicable law		<input type="checkbox"/>	Yes	<input type="checkbox"/>	No
<b>I. Declaration of applicant</b>					
<p>I _____ declare that:</p> <p style="text-align: center;">(print name)</p> <ol style="list-style-type: none"> <li>1. The information contained in this application, attached schedules, attached plans and specifications, and other attached documentation is true to the best of my knowledge.</li> <li>2. If the owner is a corporation or partnership, I have the authority to bind the corporation or partnership.</li> </ol> <p>_____</p> <p style="display: flex; justify-content: space-between;"> <span>Date</span> <span>Signature of applicant</span> </p>					

Personal information contained in this form and schedules is collected under the authority of subsection 8(1.1) of the Building Code Act, 1992, and will be used in the administration and enforcement of the Building Code Act, 1992. Questions about the collection of personal information may be addressed to: a) the Chief Building Official of the municipality or upper-tier municipality to which this application is being made, or, b) the inspector having the powers and duties of a chief building official in relation to sewage systems or plumbing for an upper-tier municipality, board of health or conservation authority to whom this application is made, or, c) Director, Building and Development Branch, Ministry of Municipal Affairs and Housing 777 Bay St., 2nd Floor. Toronto, M5G 2E5 (416) 585-6666

**A. Road Work Permit**

A Road Work Permit is required of all persons, agencies, corporations (private or public), or institutions to occupy or close any Township Road, sidewalk, boulevard, or right-of-way to complete work. Including, but not limited to, storage bin, waste bin, parked equipment, sidewalk closure, etc. Properties adjacent to Regional Roads must apply for a Region of Waterloo Work Permit.

Is a Road Work Permit required for the work being applied for under this building permit?

Yes

No

**B. Entrance Permit**

An Entrance Permit may be required of all persons, agencies, corporations (private or public), or institutions for a new entrance (driveway) or change to an existing entrance on any Township Road. Entrances on a Regional Road must apply for a Region of Waterloo Access Permit.

Is an Entrance Permit required for the work being applied for under this building permit?

Yes

No

**C. Municipal Park & Trail Property Access**

A Permission to Access Park & Trail Property Permit is required anytime a contractor or homeowner plans to enter onto Township owned parkland, greenspace, or trails with any type of equipment or vehicle for the purpose of accessing private property. This policy is aimed to control access, prevent any damage to Township owned lands, and ensure the safety of park and trail users. A Permission to Access Park & Trail Property permit is required when crossing Township lands to carry out activities on private property, including but not limited to, landscaping, pool construction, deck or fence construction, or delivery of materials. If Township owned parkland, greenspace, or trails are accessed outside of this process, the Township may hold those parties responsible for any and all resulting damages, and parties may be prosecuted to the full extent of the law.

Is a Permission to Access Park & Trail Property Permit required for the work being applied for under this building permit?

Yes

No

## Schedule 1: Designer Information

Use one form for each individual who reviews and takes responsibility for design activities with respect to the project.

<b>A. Project Information</b>			
Building number, street name		Unit no.	Lot/con.
Municipality	Postal code	Plan number/ other description	
<b>B. Individual who reviews and takes responsibility for design activities</b>			
Name		Firm	
Street address		Unit no.	Lot/con.
Municipality	Postal code	Province	E-mail
Telephone number	Fax number		Cell number
<b>C. Design activities undertaken by individual identified in Section B. [Building Code Table 3.5.2.1. of Division C]</b>			
House	HVAC – House	Building Structural	
Small Buildings	Building Services	Plumbing – House	
Large Buildings	Detection, Lighting and Power	Plumbing – All Buildings	
Complex Buildings	Fire Protection	On-site Sewage Systems	
Description of designer's work			
<b>D. Declaration of Designer</b>			
<p>I _____ declare that (choose one as appropriate):</p> <p style="text-align: center;">(print name)</p> <p>I review and take responsibility for the design work on behalf of a firm registered under subsection 3.2.4. of Division C, of the Building Code. I am qualified, and the firm is registered, in the appropriate classes/categories.</p> <p>Individual BCIN: _____</p> <p>Firm BCIN: _____</p> <p>I review and take responsibility for the design and am qualified in the appropriate category as an "other designer" under subsection 3.2.5. of Division C, of the Building Code.</p> <p>Individual BCIN: _____</p> <p>Basis for exemption from registration: _____</p> <p>The design work is exempt from the registration and qualification requirements of the Building Code.</p> <p style="text-align: center;"><b>Basis for exemption from registration and qualification:</b> _____</p> <p>I certify that:</p> <ol style="list-style-type: none"> <li>1. The information contained in this schedule is true to the best of my knowledge.</li> <li>2. I have submitted this application with the knowledge and consent of the firm.</li> </ol> <p>_____</p> <p style="display: flex; justify-content: space-between;"> <span>Date</span> <span>Signature of Designer</span> </p>			

**NOTE:**

1. For the purposes of this form, "individual" means the "person" referred to in Clause 3.2.4.7(1) (c) of Division C, Article 3.2.5.1. of Division C, and all other persons who are exempt from qualification under Subsections 3.2.4. and 3.2.5. of Division C.
2. Schedule 1 is not required to be completed by a holder of a license, temporary license, or a certificate of practice, issued by the Ontario Association of Architects. Schedule 1 is also not required to be completed by a holder of a license to practise, a limited license to practise, or a certificate of authorization, issued by the Association of Professional Engineers of Ontario.

**Appendix B:  
Additional Drawing Resources for  
Building Permit Application**



# SAMPLE FLOOR PLAN FOR BUILDING PERMIT

☉ = HARDWIRED INTERCONNECTED SMOKE ALARM AND C.O. DETECTOR WITH STROBE

**NOTES:**  
 CEILING HEIGHT = 6'-11"  
 CEILING HEIGHT = 6'-5" (UNDER BEAMS AND DUCTS)  
 WALL FINISHES - 1/2" DRYWALL  
 CEILING FINISHES - 1/2" DRYWALL \*  
 TYPICAL EXTERIOR WALL:  
 1/2" DRYWALL  
 6 MIL POLY VAPOUR BARRIER  
 2"x4" WOOD STUDS @ 16" O.C.  
 R12 BATT INSULATION  
 8" EXISTING FOUNDATION WALL  
 TYPICAL INTERIOR WALL:  
 1/2" DRYWALL  
 2"x4" WOOD STUDS @ 16" O.C.  
 1/2" DRYWALL  
 \*IF THE PRIMARY DWELLING EXCEEDS FIVE YEARS IN AGE, OTHER REGULATIONS MAY APPLY

**NOTES:**

FLOOR AREAS:  
 1ST FLOOR = 90 SQ M  
 2ND FLOOR = 110 SQ M  
 BSMT FLOOR = 90 SQ M  
 TOTAL = 290 SQ M

**THE ONTARIO BUILDING CODE DEFINES A DWELLING UNIT AS: A SUITE OPERATED AS A HOUSEKEEPING UNIT, USED OR INTENDED TO BE USED BY ONE OR MORE PERSONS AND USUALLY CONTAINING COOKING, EATING, LIVING, SLEEPING AND SANITARY FACILITIES.**

**IF THE PROPOSED SCOPE OF WORK INCORPORATES THE ABOVE ITEMS AND HAS THE ABILITY TO ACT AS A SELF-CONTAINED UNIT, THE APPLICATION WILL BE DEEMED AN ACCESSORY DWELLING UNIT AND WILL BE REVIEWED AS SUCH.**

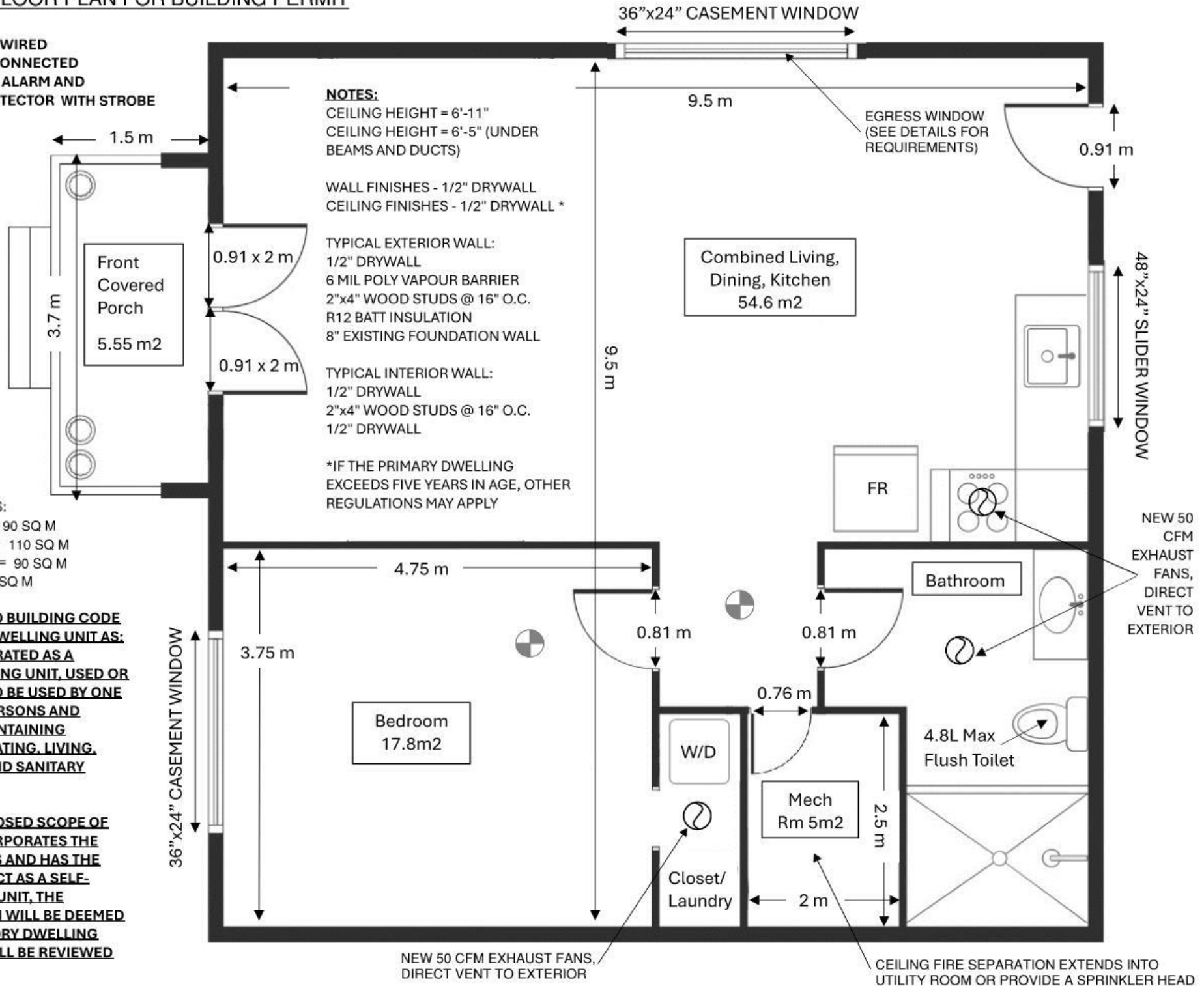



380mm (15") OR MORE FOR  
OPENABLE PORTION OF WINDOW

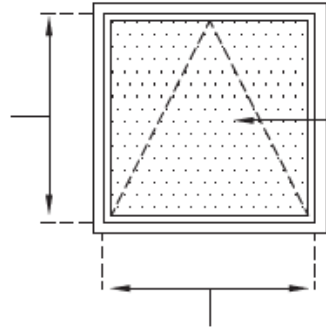

MINIMUM AREA OF UNOBSTRUCTED  
OPENING NOT LESS THAN 0.35m<sup>2</sup>  
(3.8ft<sup>2</sup>) WITH NO DIMENSION LESS  
THAN 380mm (15")

380mm (15") OR MORE FOR  
OPENABLE PORTION OF WINDOW

380mm (15") OR MORE FOR  
OPENABLE PORTION OF WINDOW

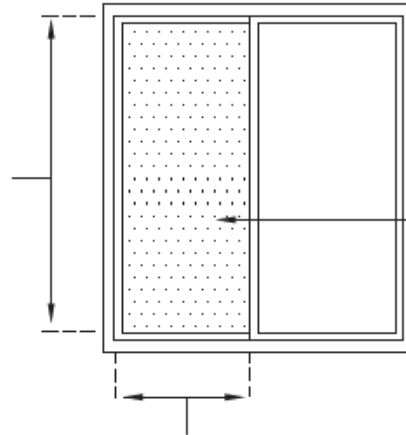

MINIMUM AREA OF UNOBSTRUCTED  
OPENING NOT LESS THAN 0.35m<sup>2</sup>  
(3.8ft<sup>2</sup>) WITH NO DIMENSION LESS  
THAN 380mm (15")

380mm (15") OR MORE FOR  
OPENABLE PORTION OF WINDOW

### EGRESS WINDOW SERVING A FLOOR LEVEL CONTAINING BEDROOM(S)

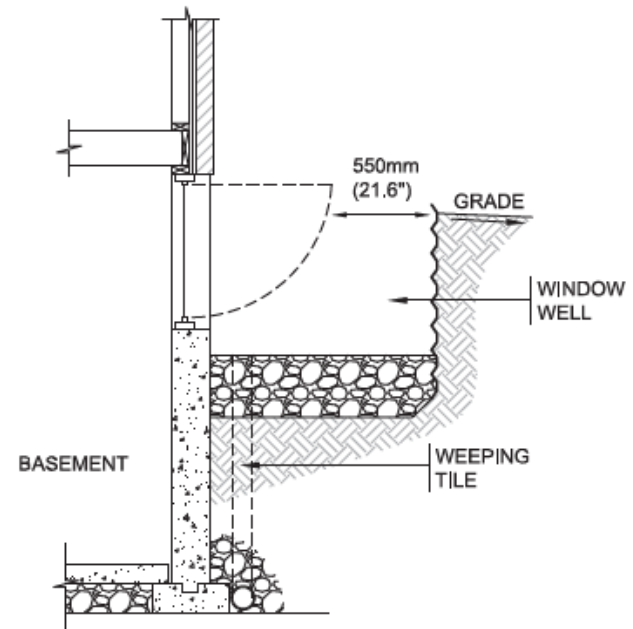
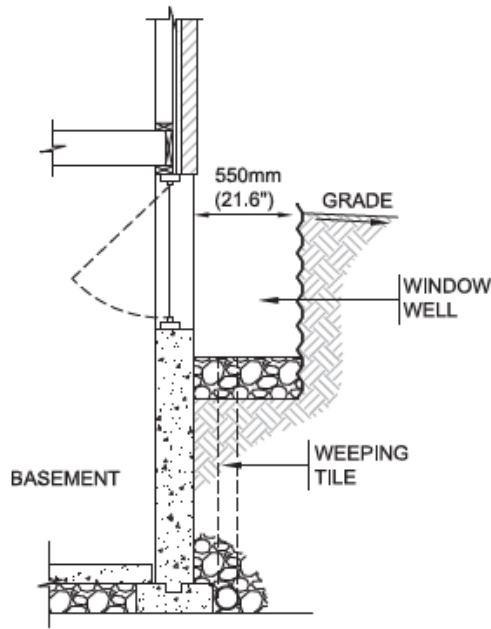

### WINDOW WELL FOR AN EGRESS WINDOW SERVING A BASEMENT CONTAINING BEDROOM(S)

# EXTERIOR BASEMENT STAIR - REINFORCING DETAIL

BACKFILL HEIGHTS GREATER THAN 1.2m (3'-11"), UP TO 2.15m (7'-0")

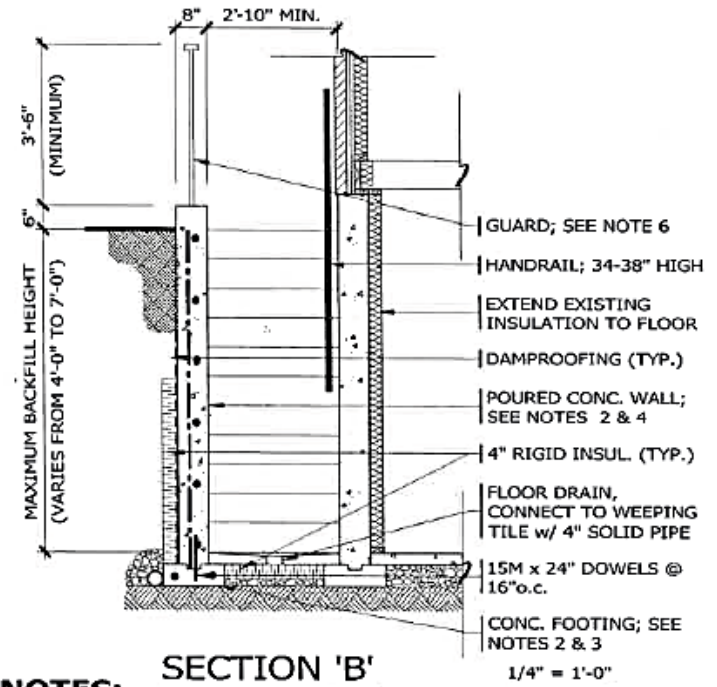
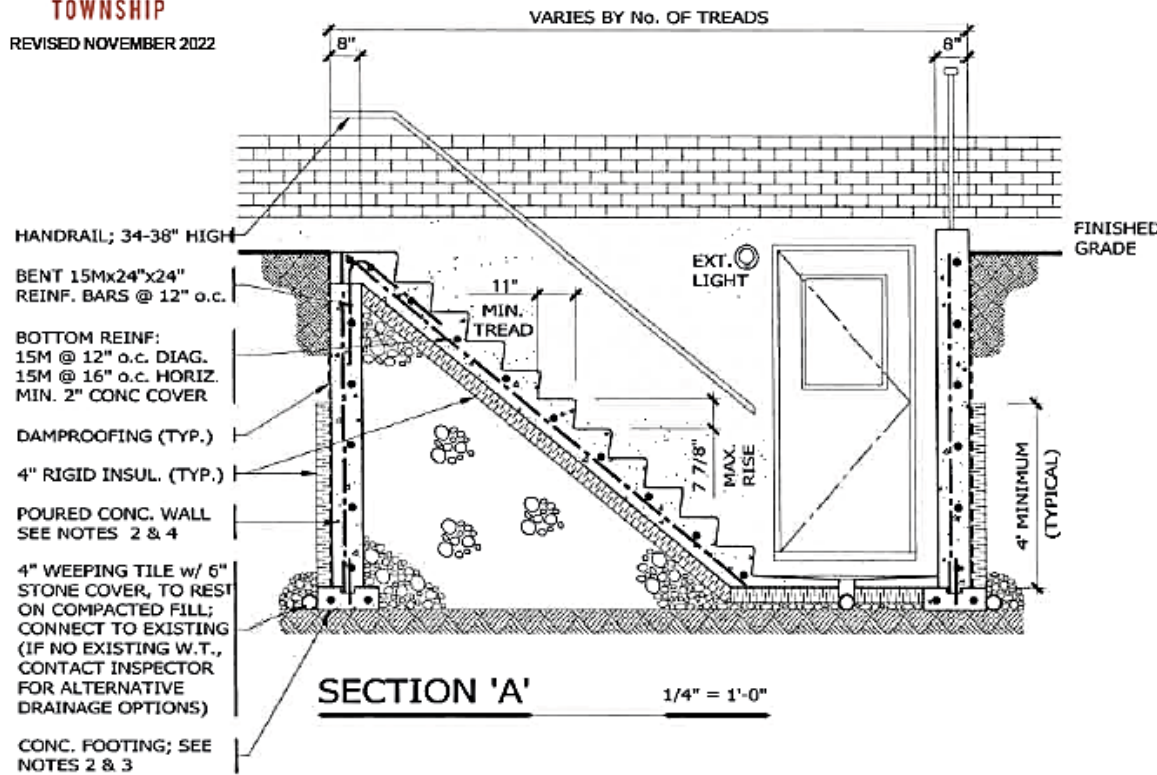

## NOTES:

### 1. GENERAL

- BACKFILL HEIGHTS OF GREATER THAN 7'-0" REQUIRE A PROF. ENGINEERS DESIGN.
- POURED CONCRETE WALLS ONLY; NOT CONCRETE BLOCK.
- POURED CONCRETE OR PRESSURE TREATED WOOD STAIRS

### 2. CONCRETE

MINIMUM COMPRESSIVE STRENGTH OF 35MPa AT 28 DAYS WITH 5% TO 8% AIR ENTRAINMENT.

### 3. FOOTINGS

16" x 8" POURED CONCRETE FOOTINGS c/w 2 - 15M BARS. FOOTINGS SHALL REST ON UNDISTURBED SOIL OR COMPACTED GRANULAR FILL.

### 4. RETAINING WALL

8" POURED CONCRETE WALL DOES NOT REQUIRE REBAR IF BACKFILL HEIGHT DOES NOT EXCEED 3'-11". PROVIDE 15M REBAR AT 16" o/c EACH WAY FOR BACKFILL HEIGHTS EXCEEDING 3'-11". AN ENGINEER'S DESIGN IS REQUIRED FOR HEIGHTS EXCEEDING 7'-0".

### 5. STAIRS

STAIRS TO CONFORM TO THE NEWLY AMENDED STAIR DIMENSIONS AS PER SUBSECTION 9.8.4. OF DIVISION B OF THE ONTARIO BUILDING CODE

RISE: MIN: 5" MAX: 7 7/8"  
RUN: MIN: 10" MAX: 14"  
TREAD: MIN: 11" MAX: 15"

**NOTE:** ALL RISERS AND TREADS SHALL BE UNIFORM.

### 6. GUARDS

GUARDS SHALL BE MIN. 36" HIGH (OR MIN. 42" HIGH IF GREATER THAN 71" FROM TOP OF STAIRS TO BOTTOM OF STAIRS), SHALL NOT ALLOW THE PASSAGE OF A 4" DIAMETER SPHERE THROUGH OPENINGS, BE DESIGNED TO PREVENT CLIMBING AND DESIGNED TO WITHSTAND THE LOADING IN TABLE 9.8.8.2. PROVIDE GUARD DETAILS TO INSPECTOR ON SITE, PRIOR TO THE INSTALLATION OF GUARD.

### 7. INSPECTIONS

AN INSPECTION OF ALL REBAR IS REQUIRED PRIOR TO POURING CONCRETE

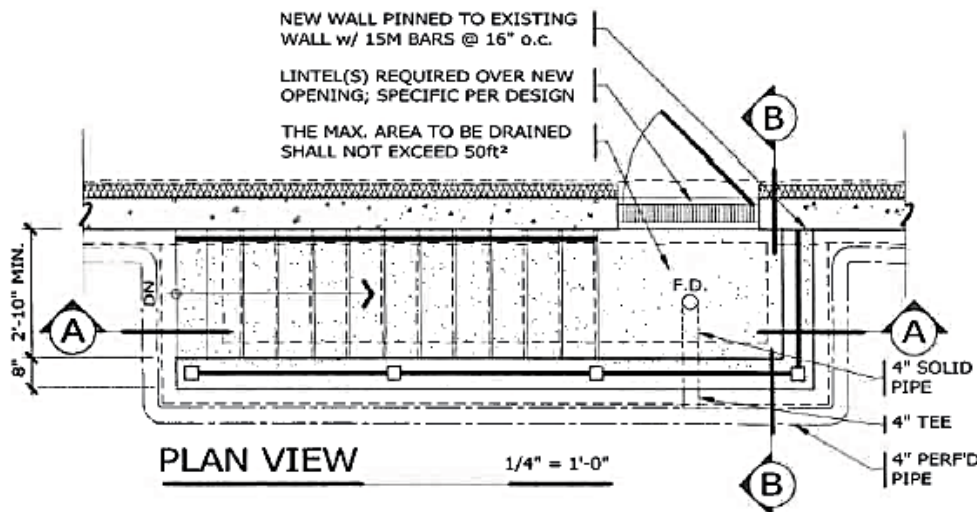

## **Appendix C: Frequently Asked Questions**



## **FREQUENTLY ASKED QUESTIONS**

### **Q: What is an Accessory Dwelling Unit (ADU)?**

**A:** An Accessory Dwelling Unit, referred to as an ADU, is an attached or detached residential unit that is entirely independent from the main dwelling. This may include tiny houses, garden suites, basement suites, granny suites, or mobile homes.

### **Q: Am I permitted an ADU on my property?**

**A:** ADUs are only permitted in the following Zones: A, R-1, R-2, R-3, R-4, R-5, R-6, R-7, MU-1, MU-3, MU-4, C-2. To find your zone, please use our Zoning By-law map on our website, or call us anytime at 519-669-1647 or 1-877-969-0094.

### **Q: How many ADUs am I permitted on my property?**

**A:** Up to two (2) ADU's are permitted in all zones. Only one (1) ADU may be detached from the primary dwelling unit. In A and R-1 zones, an Accessory building is permitted in addition to the maximum building size of the ADU, but not in other zones.

### **Q: How long will the process take?**

**A:** The zoning compliance review can take up to six weeks, after which the Zoning Compliance Certificate may be issued. The initial building permit review may take up to 15 business days, depending on the proposal and existing building type.

### **Q: How much will it cost?**

**A:** Although costs can vary significantly, the average cost to build an ADU ranges from \$100 to \$300 per square foot, whether it's attached, detached, or a conversion, in addition to the Township fees.

### **Q: How do I apply/what do I need to apply?**

**A:** There are two major steps when applying for an ADU: Obtaining the Zoning Compliance Certificate through Planning staff and applying for a Building Permit for construction. To begin the application process, follow the steps in this information package and submit initial drawings and plans to the Township alongside the completed ADU Zoning Compliance Certificate Application also found in this package.

### **Q: Can I build an accessory building and an ADU?**

**A:** In Agricultural Zones (A) and In Residential 1 Zones (R-1), a single detached accessory building is permitted and can have a maximum total size of 112 square metres over and above a permitted Accessory Dwelling Unit (ADU).

### **Q: Where can I place the entrance to my ADU?**

**A:** The entrance may be located anywhere. It is preferred that it be in the backyard as side yards must have enough space for walkways, landings, and must not encroach into protected swales, which may not always be possible. A side yard should have 5 ft to accommodate an at grade entrance, and more for a below grade entrance.

---